

MF230 Datasheet

MEDIUM-FLOW PRESSURE REGULATOR



Gas
 Liquid
 Diaphragm
 Piston
 Self-Venting
 Non-Venting
 Max Inlet: 230 bar (3,350 psi)
 Max Outlet: 10 bar (145 psi)
 Cv 1.0



INTRODUCING THE MF230...

The MF230 is a versatile and economical medium-flow pressure regulator for gas and liquid applications with a large sensitive elastomeric diaphragm.

The MF230 features a **balanced main valve** design as standard which minimises load on the seat and provides stable pressure control under decaying inlet conditions. Additionally, servicing is simplified with easy access to the seat cartridge from the base of the regulator.

SPECIFICATION

Maximum Inlet Pressure		
Seat Material	Balanced	Unbalanced
PEEK™	230 bar (3,350 psi)	100 bar (1,450 psi)
PCTFE	230 bar (3,350 psi)	35 bar (510 psi)
PTFE	50 bar (725 psi)	35 bar (510 psi)

STANDARD MATERIALS OF CONSTRUCTION

PART	MATERIALS
Body and Bonnet	AISI 316/316L Stainless Steel (UNS S31600/S31603)
Main Valve Pin	AISI 316/316L Stainless Steel (UNS S31600/S31603)
Soft Seat	PCTFE
Valve Spring	Inconel® X750
Diaphragm	FKM/FPM
Handwheel	Nylon
O-Ring Seals	FKM/FPM
Loading Spring	AISI 302 Stainless Steel (UNS S30200)

Outlet Ranges	Up to 10 bar (145 psi)
Design Proof Pressure	150% max. working pressure
Seat Leakage	In accordance with ANSI/FCI 70-3
Weight	3kg (6.6lbs)

* Pressure regulator rating may be limited by connection type, Cv and seat material

FEATURES AND BENEFITS

<p>1 LARGE SENSITIVE ELASTOMERIC DIAPHRAGM</p> <p>Provides accurate pressure regulation.</p>	<p>2 BALANCED MAIN VALVE DESIGN</p> <p>Minimises droop across the flow range.</p>	<p>3 LOW DECAYING PRESSURE EFFECT</p> <p>Stable outlet pressure under varying inlet conditions.</p>	<p>4 MAIN VALVE BOTTOM ENTRY</p> <p>Simplified servicing through base of regulator.</p>
---	--	--	--

Product availability and specifications contained herein are subject to change without notice. Consult local distributor or factory for potential revisions and/or service related issues. Pressure Tech Ltd support with product selection recommendations only - it is the users responsibility to ensure the product is suitable for their specific application requirements.



DESIGNED AND BUILT IN THE UK

PRESSURE TECH LTD
 Unit 24, Graphite Way, Hadfield, Glossop, Derbyshire, UK, SK13 1QH
 T +44 (0)1457 899 307
 E sales@pressure-tech.com
 W www.pressure-tech.com

220819

PAGE:
1 OF 4

MF230 Datasheet

MEDIUM-FLOW PRESSURE REGULATOR



- Gas
- Liquid
- Diaphragm
- Piston
- Self-Venting
- Non-Venting
- Max Inlet: 230 bar (3,350 psi)
- Max Outlet: 10 bar (145 psi)
- Cv 1.0

DRAWINGS AND INSTALLATION DIMENSIONS

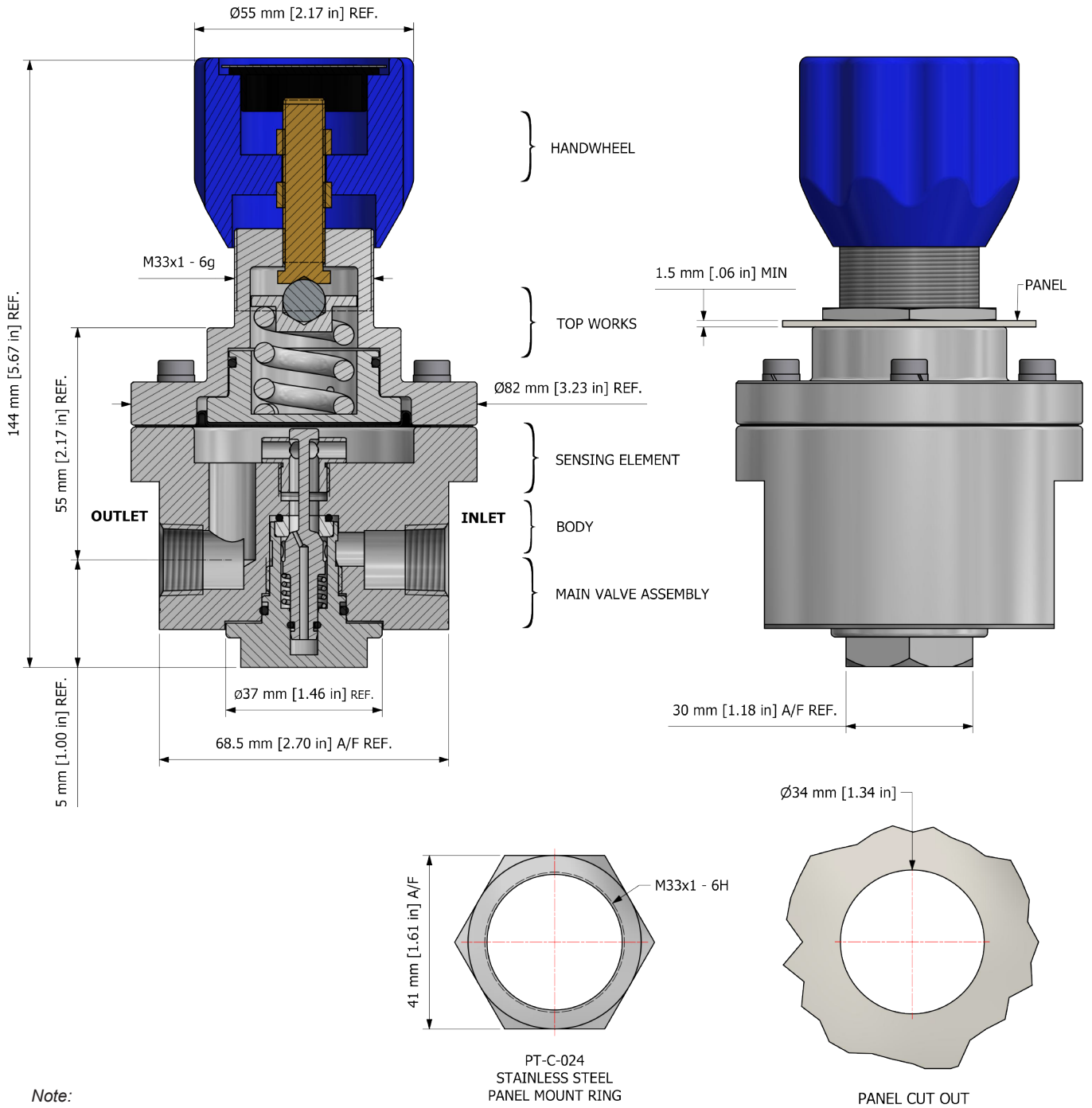

Note:
All gauge ports are 1/4" NPT as standard.

Product availability and specifications contained herein are subject to change without notice. Consult local distributor or factory for potential revisions and/or service related issues. Pressure Tech Ltd support with product selection recommendations only - it is the users responsibility to ensure the product is suitable for their specific application requirements.



DESIGNED AND BUILT IN THE UK

PRESSURE TECH LTD
 Unit 24, Graphite Way, Hadfield, Glossop, Derbyshire, UK, SK13 1QH
 T +44 (0)1457 899 307
 E sales@pressure-tech.com
 W www.pressure-tech.com

MF230 Datasheet

MEDIUM-FLOW PRESSURE REGULATOR



Gas
 Liquid
 Diaphragm
 Piston
 Self-Venting
 Non-Venting
 Max Inlet: 230 bar (3,350 psi)
 Max Outlet: 10 bar (145 psi)
 Cv 1.0

FLOW CURVE

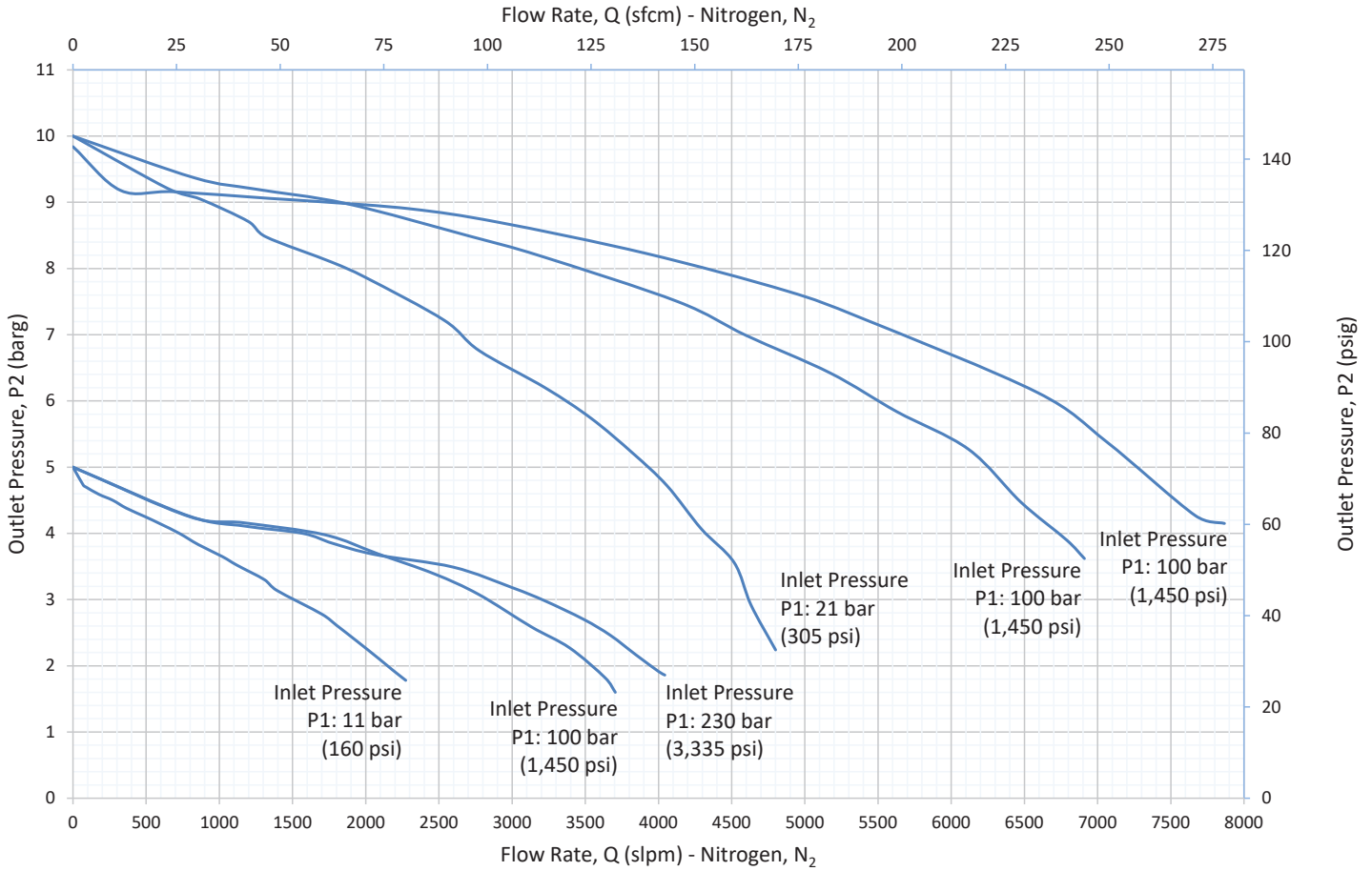

PORTING CONFIGURATIONS

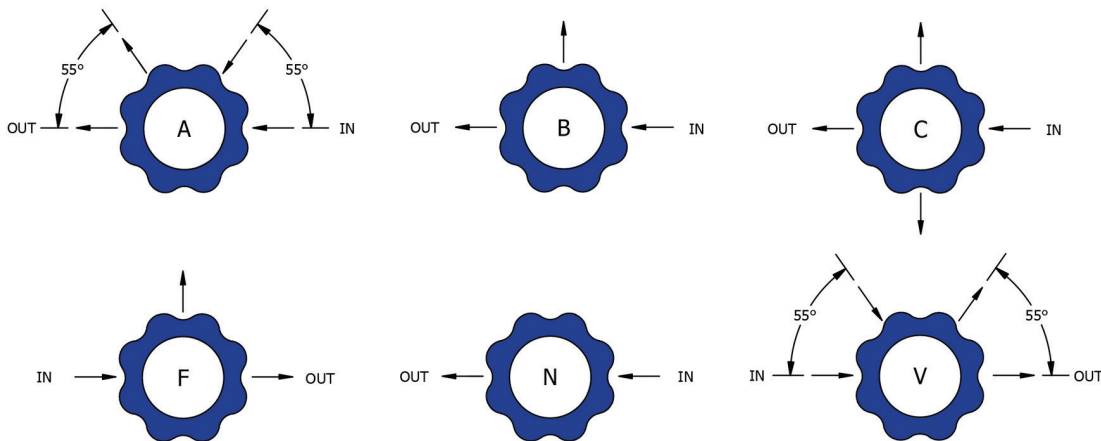

Note:

Additional porting configurations are available - please contact the office for further information.

Product availability and specifications contained herein are subject to change without notice. Consult local distributor or factory for potential revisions and/or service related issues. Pressure Tech Ltd support with product selection recommendations only - it is the users responsibility to ensure the product is suitable for their specific application requirements.



DESIGNED AND BUILT IN THE UK

PRESSURE TECH LTD
 Unit 24, Graphite Way, Hadfield, Glossop, Derbyshire, UK, SK13 1QH
 T +44 (0)1457 899 307
 E sales@pressure-tech.com
 W www.pressure-tech.com

220819

PAGE: 3 OF 4

MF230 Datasheet

MEDIUM-FLOW PRESSURE REGULATOR



Gas
 Liquid
 Diaphragm
 Piston
 Self-Venting
 Non-Venting
 Max Inlet: 230 bar (3,350 psi)
 Max Outlet: 10 bar (145 psi)
 Cv 1.0

ORDERING INFORMATION

To build a Pressure Tech part number, simply combine the characters identified below in sequence:

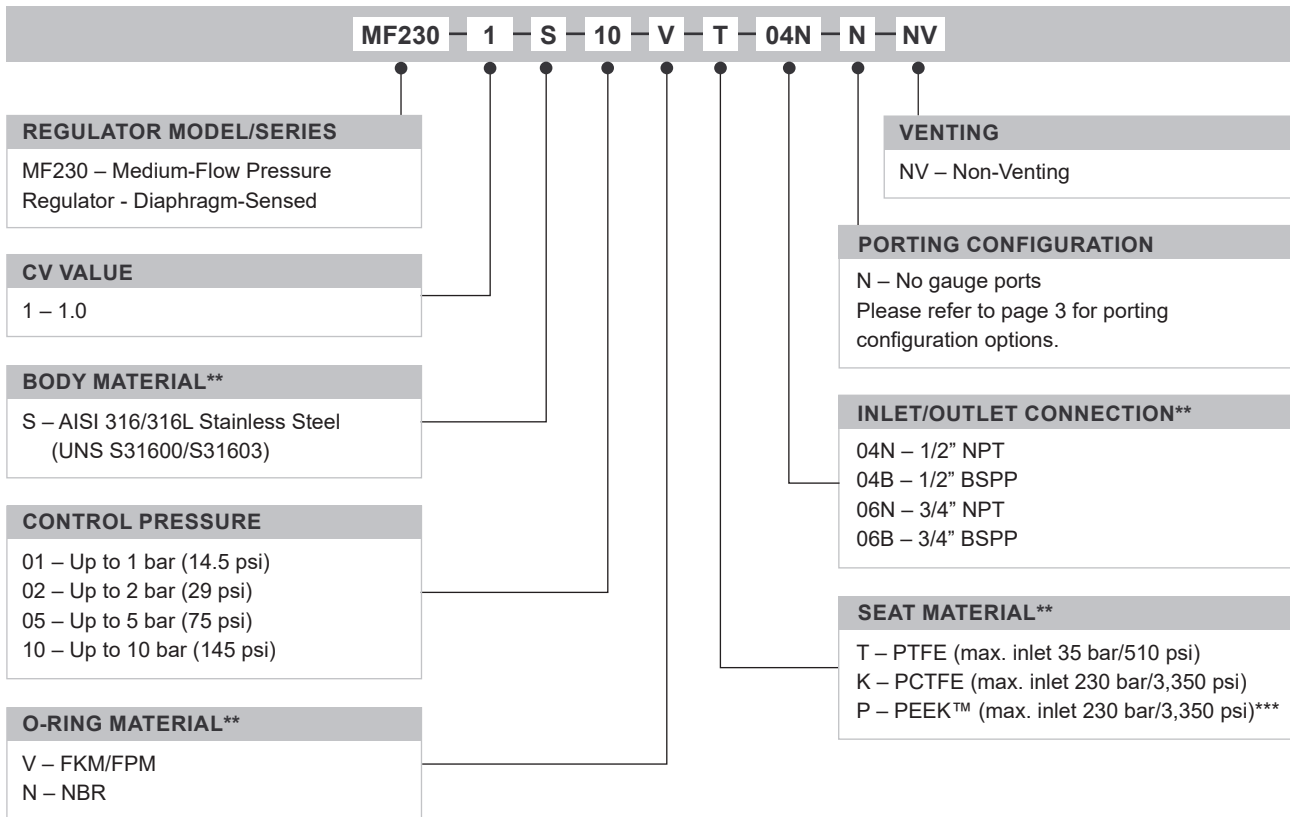

OPTIONAL EXTRAS		
	PART NUMBER	DESCRIPTION
Service Kit	SRK-MF230-1-B...	Various 'Balanced' options available
Service Kit	SRK-MF230-1-U...	Various 'Unbalanced' options available
Panel Mount Ring	PT-C-024	-

Note:
Ancillary equipment also available

TRADEMARKS: Inconel® is a registered trademark of Inco Alloys International

* Where applicable

** Other materials/connections may be available - please contact the office

*** Available up to 400 bar (6,000 psi) inlet with modification - please contact the office

Product availability and specifications contained herein are subject to change without notice. Consult local distributor or factory for potential revisions and/or service related issues. Pressure Tech Ltd support with product selection recommendations only - it is the users responsibility to ensure the product is suitable for their specific application requirements.



DESIGNED AND BUILT IN THE UK

PRESSURE TECH LTD
 Unit 24, Graphite Way, Hadfield, Glossop, Derbyshire, UK, SK13 1QH
 T +44 (0)1457 899 307
 E sales@pressure-tech.com
 W www.pressure-tech.com

220819

PAGE:
4 OF 4